



CHARGING STATION

«I-Station»



USER MANUAL

©Copyright

This documentation with all illustrations is the intellectual property of PC "AE FACTORY".
All

documentation is provided to the user for personal use only. This documentation may not
be

reproduced or provided to others without our written permission. Any violation of the law
will

be prosecuted.

Read the user manual (Manual) carefully before using the product. All
information, illustrations, tables, specifications and diagrams contained in
these

Manual were carefully compiled at the time of publication. Under no
circumstances will compliance with the information in this Manual relieve
the



user of his responsibility to comply with all applicable codes, safety
standards or

wiring regulation. The developer cannot be held liable for any direct or
indirect

damages resulting from the use or operation of the electrical circuits of the
equipment or software described herein.

The software is developed and installed exclusively for the operation of the station. The
user

is strictly prohibited from making any changes, transformations or copying the software.

The developer reserves the right to make any changes in the Manual at any time without
prior

notice.

CONTENTS

IMPORTANT SAFETY INSTRUCTIONS.....	4
1 GENERAL INFORMATION	6
1.1 INTRODUCTION.....	6
1.2 FUNCTIONALITY OF THE CHARGING STATION.....	6
1.3 SPECIFICATIONS	7
1.4 CHARGING STATION MODIFICATIONS.....	9
1.5 CONNECTORS CHARACTERISTICS.....	9
2 PACKAGE.....	10
3 MARKING.....	12
4 INSTALLATION.....	12
4.1 OPERATING LIMITATIONS.....	12
4.2 STATION INSTALLATION.....	12
4.3 STATION CONNECTING.....	16
5 OPERATION.....	17
5.1 OPERATING MODES AND ELECTRIC VEHICLE CHARGING PROCESS.....	17
5.2 CONNECTING THE VEHICLE.....	18
5.3 SAFETY MEASURE.....	19
6 MAINTENANCE	20
7 TROUBLESHOOTING.....	22
8 STORAGE.....	22
9 TRANSOPTATION.....	23
10 DISPOSAL.....	23
11 FAT CERTIFICATE.....	23
12 LIMITED PRODUCTN WARRANTY.....	24

IMPORTANT SAFETY INSTRUCTIONS

This operating manual includes the necessary sections of technical characteristics, maintenance rules, as well as safety instructions and recommendations for the operation of the station.

Before starting work, it is necessary to carefully study all the rules and recommendations given

in the instructions, and observe them during operation. This will ensure reliable operation of the product and its safety in use.

Work with the charging station, observe the safety recommendations in this manual, as well as the applicable local safety regulations and general safety regulations.

Before starting any work with the charging station, make sure that the instructions, in particular

the Safety section and the corresponding safety instructions, have been fully read by the personnel and fully understood.

Important safety instructions in this manual are indicated by symbols. These safety instructions

must be strictly followed. You should always pay attention to them and follow the safety requirements to avoid accidents, personal injury or property damage.



WARNING!

Risk of injury or death.

This symbol indicates instructions that must be followed to avoid injury, trauma or death.



ATTENTION!

Risk of material damage.

This symbol indicates instructions which, if not followed, may result in material damage, functional faults and/or breakdown of the station or the vehicle connected to it.



WARNING!

Danger - electrical current.

This symbol alerts you to potentially dangerous situations involving electric current. Failure to follow the safety instructions increases the risk of serious injury or death. Caution should be exercised, especially during maintenance and repairs.



ATTENTION!

This symbol indicates tips and information that should be adhered to in order to ensure efficient and reliable operation of the product.

Strict adherence to the safety procedures described in these operating instructions and special care when using the equipment are essential to prevent and reduce the likelihood of injury or damage to the equipment.

The manufacturer is not responsible for any direct or indirect damages resulting from the use or work with the electrical circuits of the equipment or software described in this manual.

The manufacturer is not responsible for damage and/or malfunctions caused by noncompliance with the instructions in this manual.

The manufacturer will not be liable for any personal injury or material damage, whether indirect or special, consequential, loss of business profits, business interruption or loss of business information resulting from the use of the equipment described in this manual.

In connection with non-stop improvements, the Developer reserves the right to make changes to the construction of the equipment described in this manual without prior notice.

1 GENERAL INFORMATION

1.1 INTRODUCTION

I-STATION – is a charging station (station) designed for safe and efficient charging of electric vehicles in the specially equipped places (car parks, offices, shopping malls, etc.). It can be installed indoors or outdoors. The charging station (depending on the configuration) can simultaneously AC charging up from one to three electric vehicles.

The charging station is equipped with an intellectual control system that handles communication between the station and the electric vehicle. The control and protection functions operate continuously in the system.

The station is available in several modifications. All modifications are equipped with two or three fixed cables with Type 1 / Type 2 / GB/T AC connectors and/or Type 2 socket / E-bike socket in various combinations.

1.2 FUNCTIONALITY OF THE CHARGING STATION

Mount	Wall / Pedestal
Online monitoring of device operation	+
Possibility to adjust the charge current	+
Ability to set a tariff at the charging station	+
Execution in a single body	+
Display	+
Indication of the amount of electricity consumed	+
User Interface Management	Menu functions are controlled via the app
Power cable entry from below	+
Housing material	Steel with anticorrosive coating

1.3 SPECIFICATIONS

Charging mode in accordance with IEC 61851-1	Mode 3
Nominal input voltage	3 phases, 400 V
Maximum permissible input voltage deviation, no more than	± 10 %
Rated supply frequency	50 / 60 Hz
Maximum permissible deviation of supply frequency	± 0,2 Hz
Electrical power consumed from the network, maximum	18,4 – 86 кVA
Display	<ul style="list-style-type: none"> • LED- display (20×2 symbols) • LED- display 7 (optional)
Charging station's authorization	RFID- card (IEC 14443-1); Smartphone app; Chip-tag (extra option)
Mechanical protection in accordance with IEC 62262	IK10
Case protection class in accordance with IEC 60529	IP65
Operating temperature	- 50 °C ... + 50 °C
Relative humidity	no more than 95% without moisture condensation
Weight, kg	90
Dimensions (H×W×D), mm	365×555×132
Dimensions with pedestal (H×W×D), mm	418×1983×400
Communication and protocols	
2G	GSM GPRS Class 12, Quad-band: 850 / 900 / 1800 / 1900MHz
3G/4G (LTE)	LTE Cat 1, LTE-FDD: B1/B3/B7/B8/B20/B28A; GSM: B3/B8
RFID	ISO 14443 (A) (Mifare)
Ethernet	IEEE 802.3



USER MANUAL I-STATION

Wi-Fi	802.11 a/b/g/n
OCPP	OCPP 1.6

1.4 CHARGING STATION MODIFICATIONS

The station is available in several modifications. The model range is formed depending on the type of connectors, their number, type of modem and method of station installation. When wall mounted, the station can be equipped with two or three charging ports (Type 1 / Type 2 / GB/T AC / Type 2 socket in various combinations) and an E-bike socket. For floor mounting - two charging ports: Type 1 / Type 2 / GB/T AC / Type 2 socket in various combinations. All charging cables are permanently fixed and are an integral part of the station.

1.5 CONNECTORS CHARACTERISTICS

Charging connector	Type 1 (SAE-J1772)	
		
	Maximum power per socket	9,2 kW 18,4 kW
	Maximum current per socket	40 A 80 A
	Maximum socket voltage	230 V
Cable length	6,5 m	
Charging connector	Type 2 (Mennekes)	
		
	Maximum power per socket	22 kW 43 kW
	Maximum current per socket	3×32 A 3×63 A
	Maximum socket voltage	400 V
Cable length	6,5 m	

Charging connector	GB/T AC		
			
	Maximum power per socket	22 kW	43 kW
	Maximum current per socket	3×32 A	3×63 A
	Maximum socket voltage	400 V	
Cable length	6,5 m		
Charging connector	Type 2 Socket		
			
	Maximum power per socket	22 kW	
	Maximum current per socket	3×32 A	
Maximum socket voltage	400 V		

2 PACKAGE

Wall mounting		
EV charging station I-STATION		1
User manual		1
Mounting plate		1
Screw M5 with plastic dowel		4
Pedestal mounting		
EV charging station I-STATION with pedestal		1
User manual		1
Inserts		1
Nut M16		4
Washer 16		4

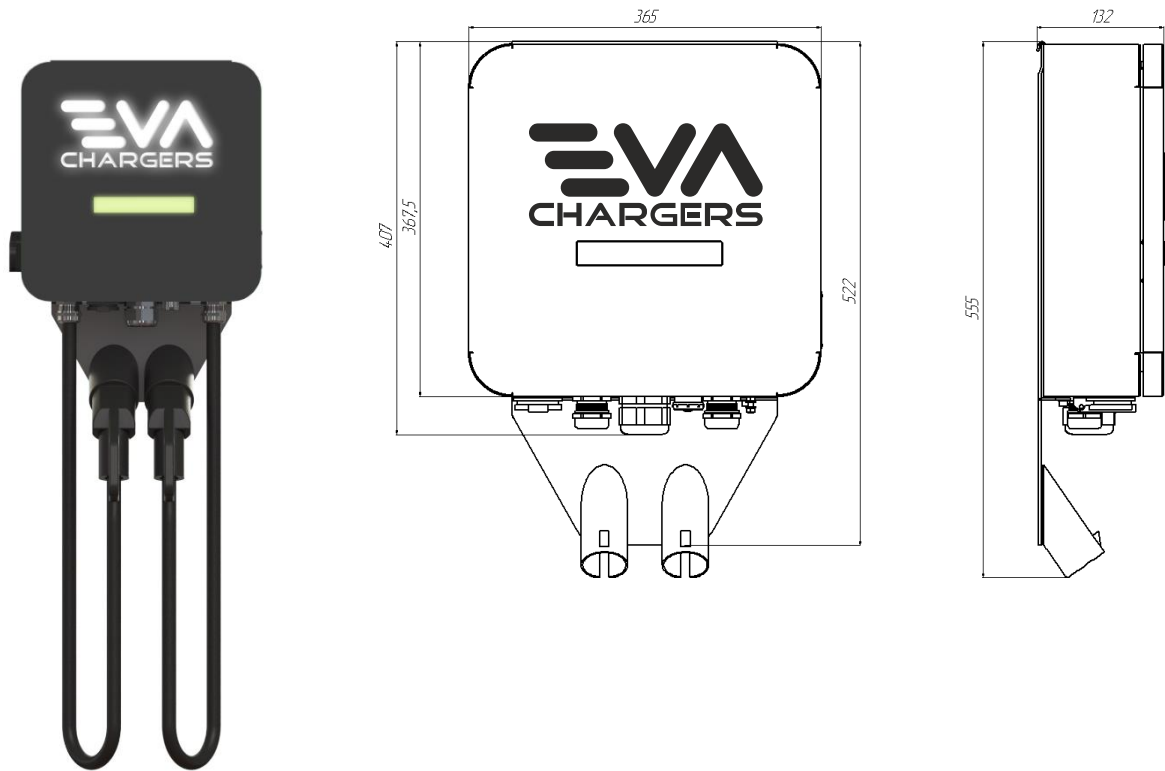

Figure 1a. Station external view and station dimensions for wall mounting

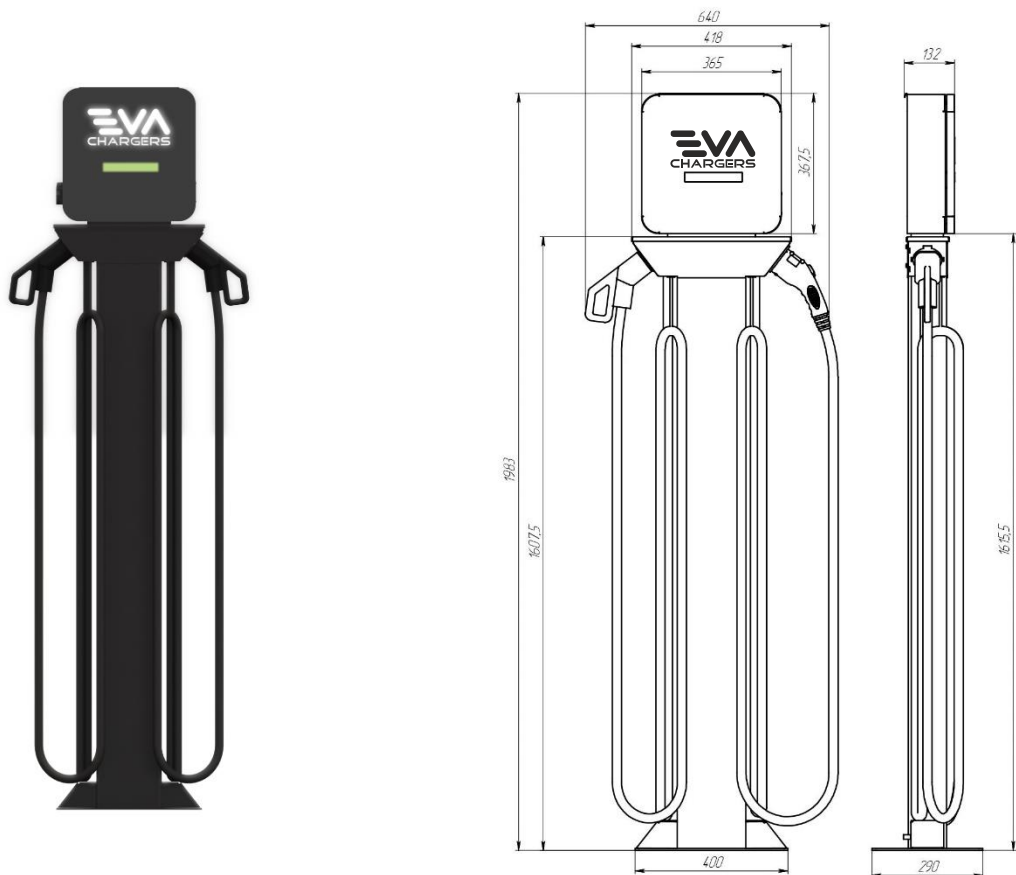

Figure 1b. Station external view and station dimensions for pedestal mounting

3 MARKING

The nameplate is located on the left side of the charging station enclosure. The nameplate specifies information such as the model, serial number and basic technical specifications.

4 INSTALLATION

4.1 OPERATING LIMITATIONS



The charging station is designed only for charging electric vehicles.

Charging only compatible electric vehicles.

Failure to comply with the requirements for operation, maintenance and repair, described in this manual, excludes any liability of the manufacturer in the event of malfunctions in the operation of the station.

The installation altitude of the charging station above sea level should not exceed 2000 m.

Follow the safety regulations to avoid injury and material damage when working with the station.

Before the station installation, you should review this manual carefully and consult with a licensed electrician, contractor, and trained installation expert to insure compliance with local building codes, safety standards and wiring regulations

4.2 STATION INSTALLATION

Make sure the installation site has adequate GSM or 4G (LTE) cellular coverage. Cellular repeaters may be required to ensure good signal strength in underground garages or other enclosed parking lots.

It is recommended to place the station under a canopy to protect it from direct exposure to atmospheric precipitation and sunlight.

For wall-mounted charging stations, a place must be prepared for attaching the bracket. When choosing the location of the station, keep in mind that there must be a distance of at least 1 meter to the left and right of the station body to any obstacle. The holes for the screws should be positioned as shown in Figure 2.

For pedestal-mounted charging stations, prepare the installation site in advance by following the instructions below.

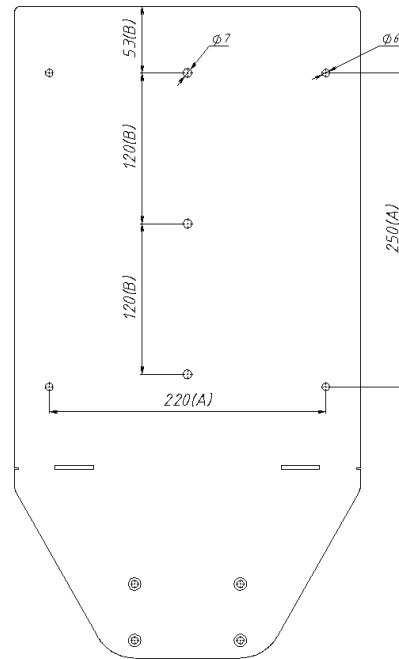
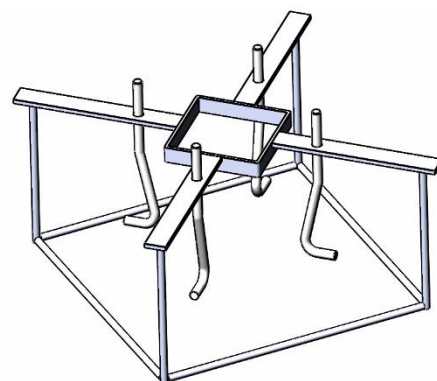
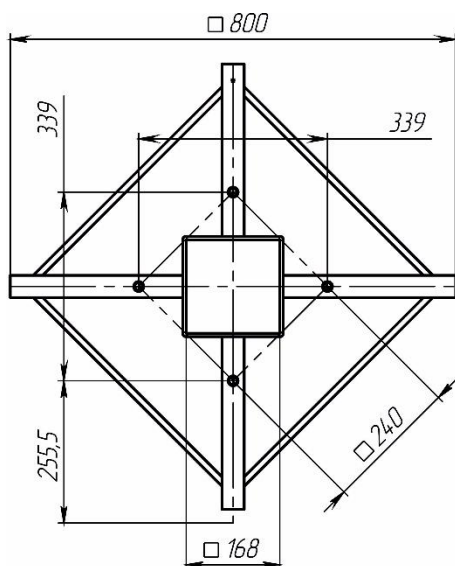

Figure 2. Mounting plate

When choosing a location for the charging station, the following conditions must be met: there must be a distance of at least 1 meter between the charging station body and a wall or any obstacle. There should be enough free space for maintenance in front and behind the enclosure.

Station is installed on a foundation (prepared concrete base) measuring 900x900x400 mm. There should be no underground cables or pipes in the area around the foundation.

The foundation is poured into a well-rammed base with a pre-laid cable duct and a placed metal insert. For the base, it is necessary to use a mixture of crushed stone with cement at least M400. The surface of the foundation must be carefully leveled to avoid distortion of the station during installation.



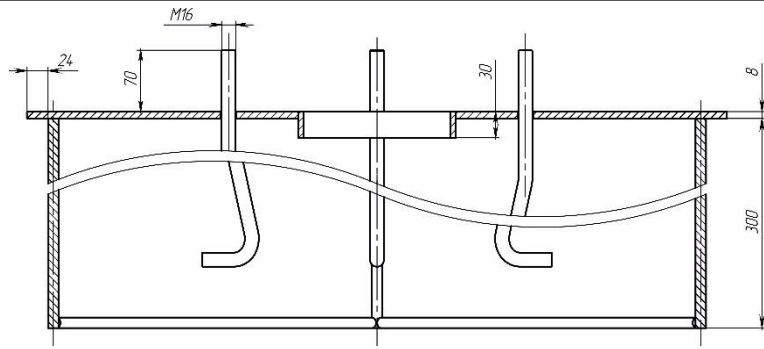

Figure 3. Inserts external view and inserts dimensions

The dimensions of the pedestal base are shown in Figure 4, the plate thickness is 5 mm.

Along with the preparation of the foundation, it is necessary to ensure the laying of an electric power cable (not included in the delivery set). The required cable length above the foundation is at least 2 meters.

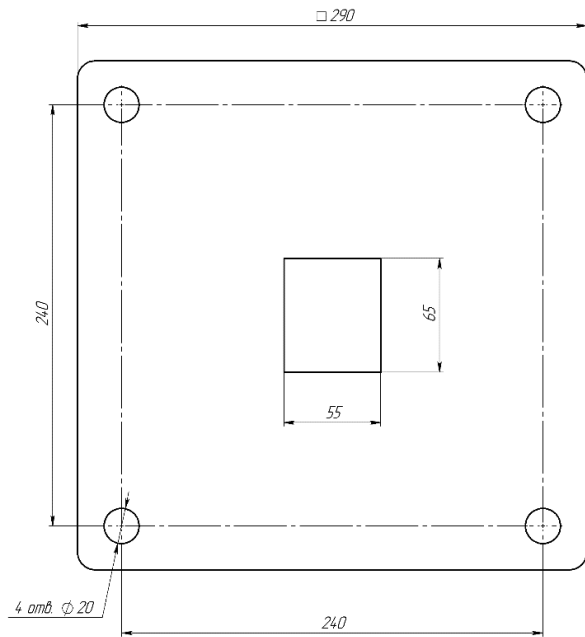

Figure 4. Pedestal base (bottom view)

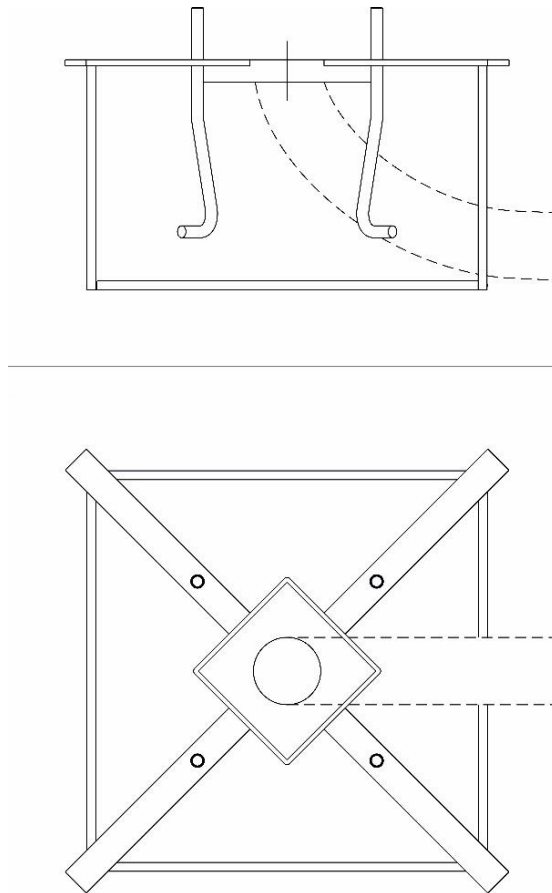

Figure 5. Station foundation



WARNING!

Only qualified personnel should connect the power cable to the AC mains..

It is recommended to select the cross-section of the power cable based on the power of the station.

Table 2. Recommended cross-section of power cable

Charging station power, kW	Cross-section of power cable, mm ²
<75	5×16
75-98	5×25
98-118	5×35
118-148	5×50

It is necessary to install an AC circuit breaker between the station and the power supply network when the power cable laying. It is recommended to use a 3-pole circuit breaker in the range from 80 A to 140 A (depending on the station power) in accordance with local building codes, safety standards and wiring regulations.

4.3 STATION CONNECTING

After transporting the charging station, before installation, make sure that all internal elements are properly fixed and there are no mechanical damages.

Check the quality of wire, loop, and connector connections. Check the tightening torque of terminals, bolts, screws, and switchgear.

The charger does not require any special adjustment or tuning before it is put into operation. Before you connect the charger, make sure that:

- The power supply cable on the mains side is de-energized by means of external disconnecting devices.
- The mains supply is connected as shown in the wiring diagram: 3 phases with separate Neutral (N) and grounding (PE) conductors
- When connecting with a 4-wire cable, carry out the protective grounding with a separate wire.

To connect the station to the electric circuit, it is necessary to open the cover of the charging station and lead the power cable through the cable entry channel to the internal part of the station.

Next, you need to connect the power supply cable to the appropriate input busbars (as shown in pic. 6). When connecting with a 4-wire cable, the external grounding should be done with a wire of a cross section of at least 25 mm² by means of a bolted connection M10 with the inscription «PE», located in the terminal compartment.



GROUNDING REQUIREMENT!

The resistance of the charging station's ground loop should not exceed 4 Ω. No additional devices are allowed to be connected to the charging station's ground loop.

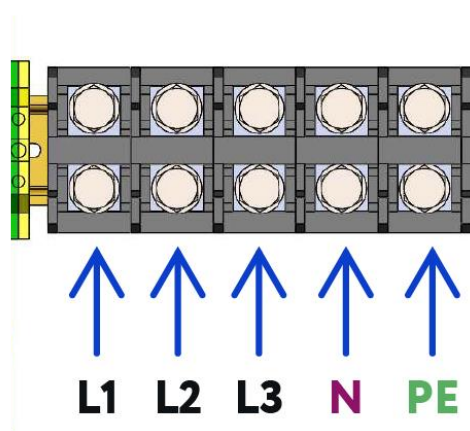

Figure 6. Input busbars

ATTENTION!

THE FIRST CONNECTION THAT MUST BE MADE IS THE GROUND WIRE TO THE GROUND BUSBAR MARKED «PE».

DO NOT SWITCH ON THE CHARGER WITHOUT A CONNECTED GROUNDING!

Non-compliance with this requirement may result in energizing the charger body, electric shock damage to the service personnel and consumers, as well as in a failure of the charger.

Then, with the help of external switching devices, it is necessary to connect the power cable to the AC mains and then move the circuit breaker to the working position.

**ATTENTION!**

Before turning on the station, contact technical support to activate the SIM-card.

To switch the charging station on it is necessary to:

1. Install mobile operator's SIM-card (if an external SIM-card is used):
 - remove the modem cover;
 - install SIM-card;
 - close the modem cover.
2. Move the circuit breaker to the operating position (up).
3. Move the circuit breaker on the switch board to the operating position (up).

5 OPERATION

5.1 OPERATING MODES AND ELECTRIC VEHICLE CHARGING PROCESS

Information about the operating modes of the charging station (the state of the connectors and the charging parameters) are displayed on the display. Also, the display shows data about software versions, modem number, station number in "AE FACTORY" billing, mobile network status, etc.

The information shown on the display depends on the software version and may differ from version to version.

Autoenterprise
V : 4.12.1784
Z120359

After the supply voltage is applied, the station display shows information about the software version and the serial number of the modem.

In case of malfunctions in the operation of the charging station, you must inform the serial number of the modem to the service center for diagnostics and restoration of work.

Type1A: Ready
Connect plug

In standby mode, the display shows information about the status of the connectors.

Type1A: Charging
0 : 00 : 23
31.4A/211V

In car charging mode, the LCD display shows information about charging parameters: charging time, voltage level, current amperage, etc.

5.2 CONNECTING THE VEHICLE



5.3 SAFETY MEASURE

The control system of the charging station is powered from the mains through an additional circuit breaker.

The output cable is connected via cable sleeve / cable glands.

6 MAINTENANCE

WARNING!



All maintenance work must be performed by the manufacturer's representative or a qualified technician. Do not attempt to perform routine maintenance yourself; this may result in electric shock and/or loss of functionality of the charging station..



CAUTION!

Improper maintenance may result in serious injury or equipment damage. For this reason, this work should only be performed by authorized, trained personnel who are familiar with the operating principles of the plant and strictly follow all safety instructions.

The use of explosive or flammable cleaning products poses a risk of fire or explosion.

Do not store flammable or explosive liquids near the charging station.



WARNING!

Before carrying out any maintenance work, ensure that the charging station is de-energized.



INFORMATION

To ensure maximum service life of the charging station, it is recommended that the interior be kept clean regularly.

Only the manufacturer, an authorized service technician, or technically qualified personnel may replace damaged charging station or its components.

In the course of operation the following maintenance are carried out:

- Visual inspection for overheating of equipment; check, pulling connections;
- Identification of defective parts, assemblies, their repair and replacement.

Before performing any maintenance or cleaning work on the charging station, or working on any circuits connected to the charging station, authorized service personnel must disconnect all AC power from the charging station to reduce the risk of electric shock.

Perform a preventative check of the charging station at least once every 6 months. To do this, it is necessary to disconnect the charging station from live circuits, thoroughly clean its body, contacts from dust and dirt, and check the quality of fastening of the wires. The terminal block screws and wire lugs must be tight and the insulation must not be damaged.

It is strictly prohibited to modify or make changes to the design of the charging station in any way without the written consent of the manufacturer!

All signs, stickers and pictograms placed on the charging station must be visible and legible. Signs, labels or pictograms that are damaged or unreadable must be replaced immediately. Please contact the manufacturer to discuss such issues.

7 TROUBLESHOOTING

Failure mode	Potential cause	Remedy
Lost connection with server	Modem failure / SIM card inoperative	Replace the modem / check the status of the SIM-card
	Poor mobile signal strength / Modem antenna is out of order / Station is out of range of the mobile network	Replace antenna with a more powerful
Charging cable or connector fault	Depreciation, careless handling of equipment	De-energize the device. Contact to Customer Service to replace charging cable or connector.
The charging station display does not work (there is no information on the station display)	No input voltage	Find out the reason for the lack of voltage. Restore power supply.
	Circuit breaker(s) tripped off	Bring circuit breaker(s) to operating position
	Display is out of order	Contact to Customer Service
Other malfunction	Malfunctions caused by external and internal factors	Contact to Customer Service

CUSTOMER SERVICE

You can write an email or call to the tech support using the contact page on our web-site

evachargers.com

8 STORAGE

The charging station is supplied in individual factory packaging. Remove all packaging before installing the station.

STORAGE CONDITIONS:

- Charging station must be stored in its original packaging.
- Charging station should be stored in dry heated rooms, free of dust, corrosive and oily materials.
- Keep the charging station in the warehouse with the appropriate weather protection.
- Keep away any sharp object from the charging station, cords or plugs/connectors.
- During storage, the charging station must be protected from shocks.
- Avoid extreme temperature fluctuations.
- Storage temperature range: 5 °C to +40 °C (41 °F to 104 °F).
- Humidity: < 75%.

9 TRANSPORTATION

Charging stations must be transported in transport packaging by rail, road and air transport without limiting the transportation distance, taking into account the rules for the transportation of goods in force for these types of transport.

When transporting, consider the center of gravity of the charging station to minimize the risk of tipping over.

During transportation, the charging station must be reliably protected from movement inside the vehicle. To securely fasten the station, straps and soft inserts should be used, and measures must be taken to protect the station from damage by other transported objects.

In this case, the station must be protected from mechanical movements (fastening) and precipitation.

The weight of the charging station in the transport package does not exceed 100 kg.

10 DISPOSAL



ATTENTION!

The symbol with the crossed-out waste container means that electrical and electronic devices including their accessories must not be disposed in the household garbage!

Please observe the regulations regarding disposal of electric appliances and electronic devices!

Electronic components of the charging station must be disposed in accordance with the current legislation regarding the disposal of electronic and electrical waste.

11 FAT CERTIFICATE

THE CHARGING STATION

I-STATION <small>MODEL/MODIFICATION</small>	<small>PRODUCT NAME</small> XXXXXXXXXXXX <small>SERIAL</small>
manufactured and accepted in accordance with the requirements of EN 61851-1:2019 <small>STANDART</small>	
and recognized as fit for use	

Head of Quality Control Department

LS

SIGNATURE

FULL NAME

DATE

12 LIMITED PRODUCT WARRANTY

This Limited Product Warranty (“Warranty”) applies to the charging station I-STATION (“Station”) purchased from manufacturer or one of its authorized distributors.

Subject to the exclusions set forth below, manufacturer warrants that the Station will be free from defects for a period of one (1) year after the date of delivery manufacturer’s warehouse (“Warranty Period”), unless manufacturer and its direct customer (“Customer”) explicitly agree otherwise in writing.

Customer may transfer the Warranty to its customers (“Station's Owner” or “Owner”).

WARRANTY SERVICE

Within the Warranty Period, upon verification of a warranty claim, manufacturer will, at its sole discretion, repair or replace broken component (that was damaged in normal use) at no charge to Owner for material and/or labour. Owner pays any transportation costs associated with the replacement / repair of components (to the manufacturer factory or any other repair location indicated by manufacturer).

If the repair issue cannot be resolved remotely, Owner shall, at its own expense, ship the Product(s) to a Repair Centre, after receipt of respective instructions.

To obtain the necessary instructions you must contact to Customer Service at evachargers.com.

Owner assumes risk of any shipping related loss or damage.

If the fault is covered by this Warranty, manufacturer will repair or replace the Product(s) and ship it back to the Owner via ground transportation at manufacturer’s cost.

The out-of-warranty Station or station ineligible for warranty service will be repaired or replaced at Owner’s request according to the preliminary agreement on payment and shipped back at Owners expense.

All replaced parts are the property of manufacturer.

The warranty does not apply to equipment damaged as a result of:

- incorrect electrical, mechanical connection;
- misuse or Station usage beyond its intended purpose;
- modification or changes in the design of the product without written manufacturer approval;
- incorrect installation, assembly/disassembly or relocation of the Station unless performed by manufacturer or authorized service personnel;
- maintenance and repair of product performed by an unauthorized or unqualified personnel;

- failures from the grid;
- external damages (including physical damage from being struck by a vehicle) or violation of the rules of transportation and storage;
- use of interfaces or parts not provided by manufacturer;
- accidents, acts of nature or other causes beyond manufacturer's control;
- vandalism.

The manufacturer is not responsible for the possible costs associated with the installation and removal (dismantling) of the warranty equipment, as well as for damage caused to other equipment in the possession of the consumer, as a result of malfunctions (or defects) arising during the Warranty period. Furthermore, damage to the electrical vehicle itself is never covered by this Warranty.

Manufacturer or its authorized distributors will not be liable for any indirect, incidental, special, punitive or consequential damages, even if manufacturer knew or should have known of the possibility of such damages.

The cumulative liability of manufacturer or its authorized distributors for all claims whatsoever related to this station or the service will not exceed the price of this station.

ADDITIONAL INFORMATION

Owner is responsible for the proper installation and maintenance of the Station.

This Limited Product Warranty is not transferable by the Station's Owner to anyone else.

PC "AE FACTORY" reserves the right to update any information, illustrations, sheets, specifications and diagrams contained in these Manual at any time without prior notice in respect of technical developments.

All inquiries or claims made under this Limited Product Warranty must be address as follows: evchargers.com